

Servo EE Finder

1. GENERAL

This unit consists of the main body which includes the electronics, the battery case, and the EE arm.

By installing this Servo EE Finder on the F-1 instead of Eyelevel finder, the Canon F-1 which was previously a maximum aperture T.T.L camera employing a following needle system, can be changed to a maximum aperture T.T.L system EE camera.

Also, by attachment of Motor Drive Unit, completely automatic photography is possible.

2. SPECIFICATIONS

- 2.1 Metering
 - 2.1.1 Light sensitive element: 2 CdS cells used
 - 2.1.2 Metering method: Maximum aperture center weighted system metering
(2 CdS cells are arranged at both sides of the of pentaprism eyepiece.)
 - 2.1.3 Metering range: ASA 100: EV3 to EV19 (50mm 1 : 1.4)
 - 2.1.4 Film speed: ASA 25 to 2000, 25.. 50...100.. 200...400..
800.. 1600.
 - 2.1.5 EE operation: Actuated by pressing lever switch
Also locked by means of dial switch
 - 2.1.6 Meter Servo motor system
 - 2.1.7 Meter window: Meter indication window is provided at the right side of the finder field.

- 2.1.8 Metering possible lens: FD Lens group.
- 2.2 Finder (Same type as F-1 Eyelevel Finder)
- 2.2.1 Eyelevel system with pentaprism:
Equipped with Eye cup Eyepiece.
Eyesight correction lens are also available.
- 2.2.2 Finder information: Warning mark, aperture value aperture needle.
- 2.2.3 Finder magnification: 0.77 (50mm 1 : 1.4)
- 2.2.4 Field size: 97% of actual film frame
- 2.3 Power supply: UM3 dry cell: 8 or 10 or, NiCd 500FZ: 2
(Total voltage : 12 or 15V)
The batteries are accommodated into the battery case and connected to Servo EE Finder.
Cord 12V2E is used to connect the battery to the finder.
(The finder can also be operated by a power supply.)
- 2.3.1 Power switch is provided.
- 2.3.2 Battery checker: Provided: Lamp comes on by pressing push-button if voltage is sufficient.
- 2.4 Compensation of maximum F No.
- 2.4.1 Compensation of aperture value in the finder is performed manually.
- 2.4.2 Compensation scale:
- 2.5 Installation on camera
- 2.5.1 Install the Servo EE Finder on the camera body after removing Eyelevel

Finder in the same manner as with the eyelevel finder.

2.5.2 Connect the battery case to the Servo EE Finder with the power cord 12V2E.

2.5.3 Mount EE arm setting the main switch to "M"

2.6 Eyepiece shutter: Provided

2.7 Dimensions and weight: 75 x 65 x 68mm (2 15/16 x 2 9/16 x 2 5/8 in. approx.)
417 g (14.7 oz. approx.)

3. RELATED PARTS

3.1 EE arm

3.2 Battery case

3.3 UM3 battery magazine

3.4 NiCd battery holder

3.5 Eye cup

3.6 Power cord 12V2E

3.7 Case

3.8 UM3 dry cell

3.9 NiCd 500FZ

3-10 Pentaprosom cover

3.11 Battery connector (When using by attachment of motor drive unit.)

4. EXPLANATION OF MAIN SPECIFICATIONS

4.1 Exposure meter mechanism (Servo EE)

4.1.1 Fundamental circuit

The exposure meter of the Servo EE Finder comprises the bridge circuit shown in Fig. 1. The resistance value of CdS varies as the object brightness changes, and the moment the bridge circuit becomes imbalance current flows into the motor to turn, the variable resistor is adjusted by the motor, and the motor stops when ratio of $R_c : R_1$ becomes equal to that of $R_v : R_2$.

Correct exposure is automatically set by actuating the aperture signal pin of Lens, through the EE arm.

4.1.2 Compensation for Max. aperture

When employing Lens with different Max. apertures, compensation by means of Max. F Dial is necessary. When the Max. aperture is set to the index mark, turning Max. F Dial, the meter indication plate moves by the mechanism shown in Fig. 3.

4.2 Finder information

When looking through the finder, warning mark, aperture scale and needle are observed at the right side of the finder field.

Finder information is almost the same as F-1's. When Lens with different Max. aperture is installed, if setting Max. F Dial manually, the meter indication plate slides and the Max. aperture of Lens positions just under the upper warning mark.

The upper warning mark is fixed, while the lower one is mounted on the meter indication plate and moves together with the aperture value.

4.3 Eyepiece shutter

Since CdS of this Finder is located near Eyepiece Lens, it is affected by light entering through the finder.

The CdS is seldom affected by entering light when one is looking through the finder, but while photographing by the self-timer, or taking automatic photography with the motor drive unit, close the Eyepiece shutter.

4.4 Operation range of exposure meter

Metering range of the exposure meter is between EV 3 and EV 19 at ASA 100, however when photographing with EE actuated (with main switch set to "L"), shutter speed faster than 1/8 sec must be used.

If the slow speed shutter is released with EE left activated, the mirror springs up, resulting in no light reaching the CdS. Therefore, the motor is energized and the aperture is opened, resulting in an over-exposed picture. (In the exposure meter provided with ammeter such as EXEE, the above trouble will not occur because the meter needle is clamped when shutter is released.)

At a shutter speed faster than 1/8 sec, the mirror operates so fast that the CdS does not respond and no change occurs in the aperture during shutter release.

4.5 Switch

The switch operation is shown in Fig. 5. How to use is as follows.

(1) Main switch "M"

a. When installing EE coupling arm:

Upon setting the main switch to "M", EE Signal plate goes down to the lowest position, and EE coupling arm can be installed at its proper position by clamping the screw fitting the dowel of EE coupling arm to the hole.

b. When using manual diaphragm mechanism:

Even if the manual diaphragm mechanism is used, releasing the aperture ring of Lens from EE position when the needle in the finder stays at a certain aperture value other than the minimum value, it is impossible to stop down beyond the aperture value at which the needle pointer stays. This is because that when EE signal plate remains at a certain aperture value, the aperture signal lever also stops at an irregular position. Therefore, whenever the manual diaphragm mechanism is used, the main switch must be set to "M".

(2) Main switch - "OFF"

The switch of the exposure meter circuit is turned off. The exposure meter does not operate.

(3) Main switch - "OFF" and lever switch - "ON"

When the lever switch is pushed down to the arrow-mark side with the main switch off, the lever switch is turned on at only this time, permitting

measurement of light. Upon releasing the switch from finder, the needle is clamped.

This Servo EE Finder is useful for metering at the shutter speed slower than 1/8 sec and then taking a picture, or for taking another shot with the needle left clamped.

(4) Main switch "L"

When the main switch is set to "L", the switch of the exposure meter is kept ON. Therefore, EE photography is possible.

4.6 Checker

If the lamp comes on when the checker button located at the upper part of Eyepiece Lens is pressed, it means that the battery is fully charged.

Limited voltage: 7V

With this checker, voltage can be checked at any time of shutter speed or aperture.

4.7 Power supply

The battery case is used with Canon cord 12V2B.

Eight or ten UM3 dry cells, or NiCd cell are available. When using this Servo EE Finder together with Motor drive unit, connect the battery connector to the battery case.

5. CAUTIONS FOR USE

5.1 When installing the Servo EE Finder on F-1, it is desirable that the shutter speed of F-1 be set to any position other than 1/60 sec. In the case of 1/60 sec, mount the Finder with the Finder mounting button depressed.

5.2 Install EE coupling arm after connecting the power source to the Finder, setting the main switch to "M" which lowers the EE signal plate to the lowest position.

5.3 Be sure to set ASA speed. Set ASA speed on the shutter speed dial of Servo EE Finder but not ASA speed of F-1.

5.4 Set the Max. F Dial. Even if one forgets to set the Dial, appropriate exposure can be obtained within the range of aperture of Lens used although

the aperture readout value will not coincide with the warning mark position occasionally.

- 5.5 Whenever using the manual diaphragm mechanism, set the main switch to "M".

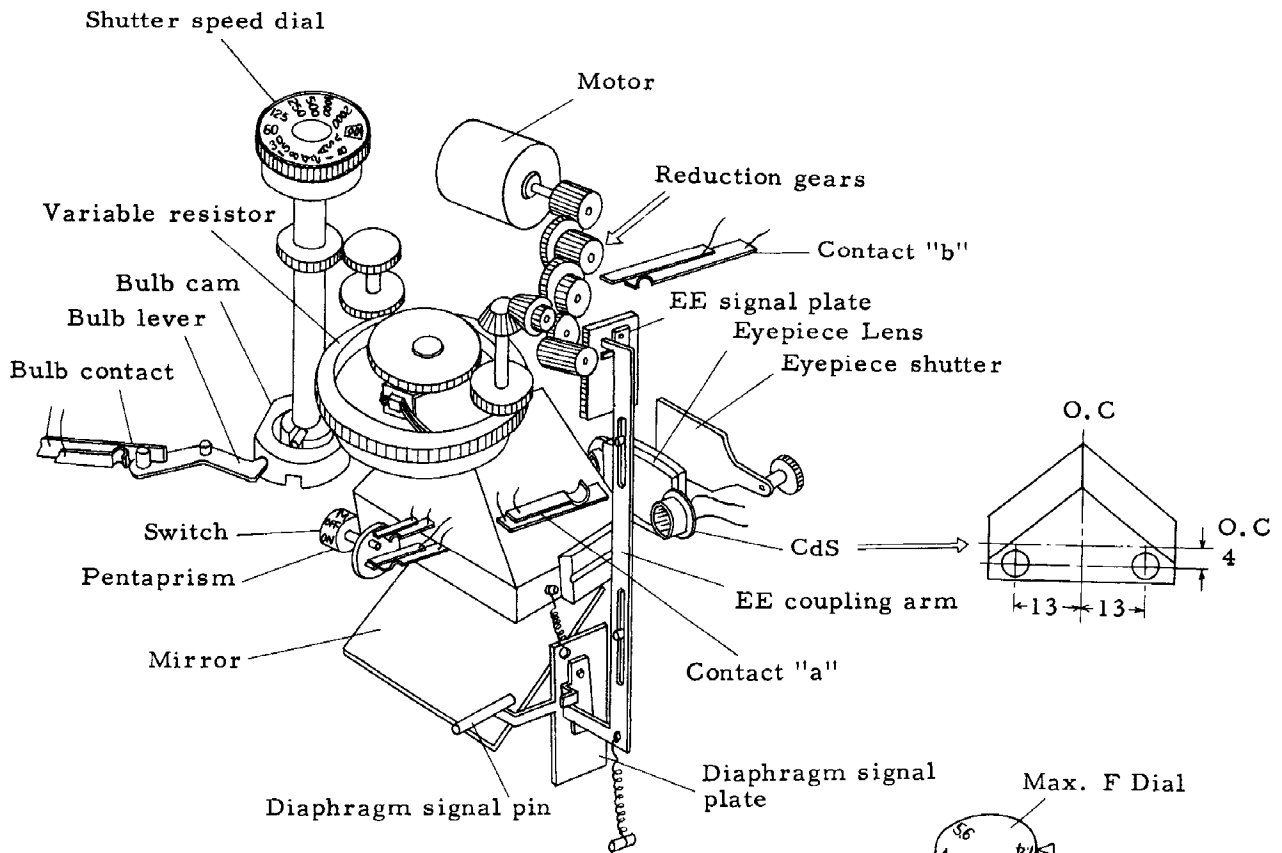
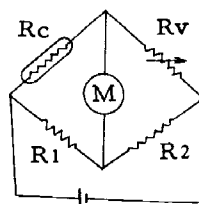

Fig. 2 Illustration of Servo EE



Rc: CdS
 Rv: Variable resistor
 R1 R2: Fixed resistor

Fig. 1 Fundamental circuit diagram of exposure meter

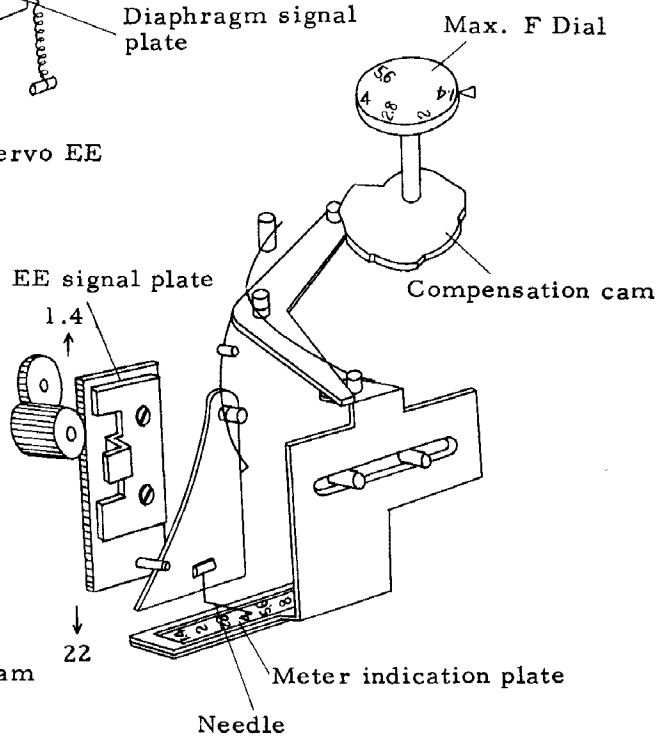

Fig. 3 Illustration of Max. F No. compensation mechanism

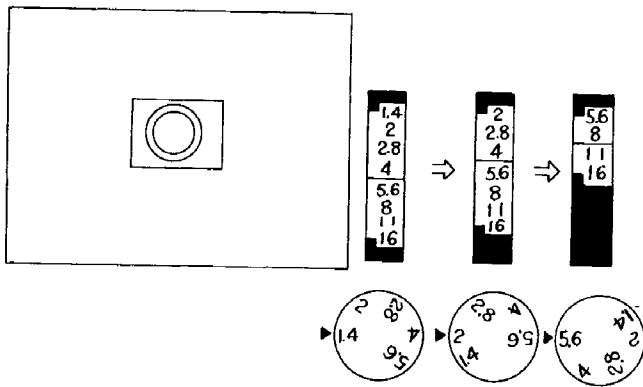
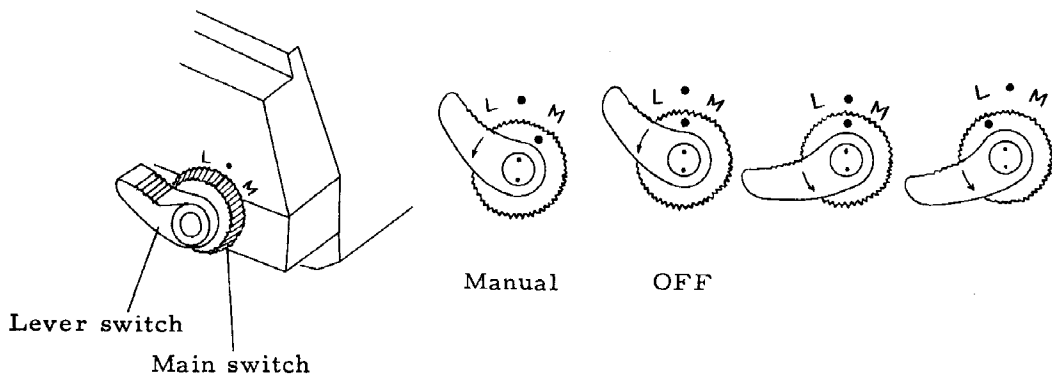

Fig. 4 Finder interior information



CONTENTS

	Page
Repair Guide General	1
1. Disassembly	2
1.1 External Parts	2
1.2 Main Base Plate	3
1.3 Pentaprism	4
1.4 EE Base Plate	5
2. Preliminary Adjustment	6
2.1 Lock Claw Position	6
2.2 Clutch Position	6
2.3 Bulb Switch	6
2.4 Finder Information	7
2.5 Aperture Control Lever Position	8
2.6 Contacts (43-5271) and (43-5266)	8
3. EE Adjustment	9
3.1 Variable Resistor	9
3.2 EE accuracy Adjustment	9
3.3 Checker	10
3.4 Miscellaneous	11
4. Backlash Adjustment	11
4.1 Motor and Reduction Gears	11
4.2 Motor Base and Main Base Plate	12
4.3 Main Base Plate and EE Base Plate	12
4.4 Gear	12
4.5 Shutter Speed Dial and Sleeve Gear	12
5. Electronic Circuit Adjustment	13
5.1 Selection of transistors	13
5.2 Constant voltage power supply circuit	13
5.3 Bridge circuit	13
5.4 1st-stage amplification circuit	13
5.5 2nd-stage amplification circuit	13

REPAIR GUIDE GENERAL

To measure meter accuracy, an F-1 and a Standard Lens (FD50mm 1 : 1.4) must be used, and aperture diameter should be measured with the EE Arm installed. Amount of light on film face must also be measured.

The CdS and the variable resistor are a high quality matched set and they must be replaced as a set.

For power an external power source is employed, normally 12V. Make sure that the camera works properly even at 7 and 15V.

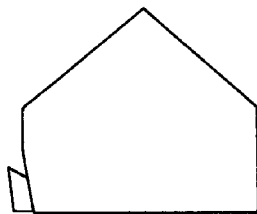

F-1, Booster

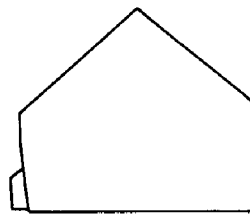

Servo EE

The finder information system of the Servo EE Finder differs from that of F-1 and Booster T Finder in mechanism. Therefore, the Pentaprism of this Finder cannot be used for F-1 and Booster T Finder.

For repair of the electric circuit, unit replacement is the usual method; however, if an oscilloscope or vacuum-tube voltmeter is available, it is possible to adjust the circuit. Partial adjustment of the electric circuit is described at the end of this manual.

1. Disassembly

1.1 External Parts

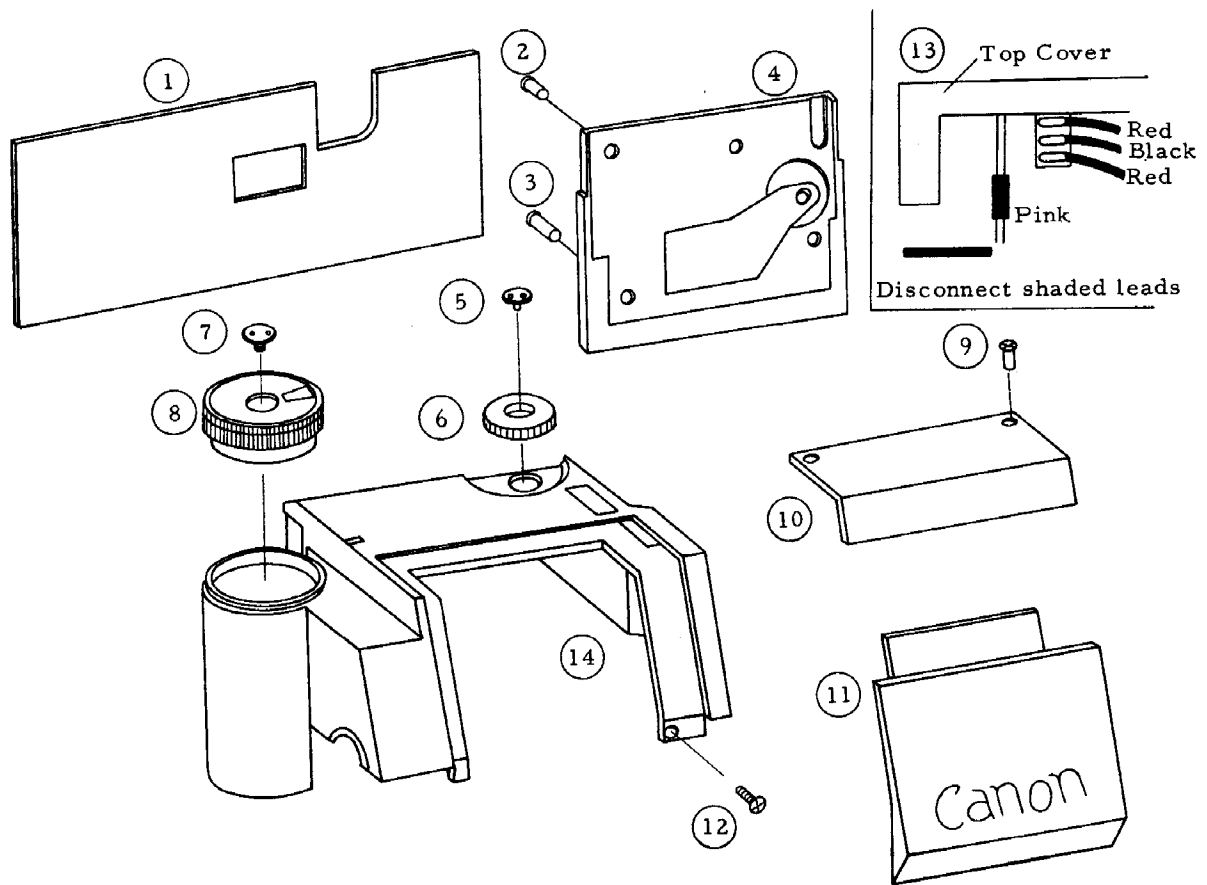

Remove the following parts in the sequence shown below.

Back Cover (4)	1	<u>Leather</u>	_____	2	<u>Screw x2</u>
		43-5307			X18-170408
	3	<u>Screw x2</u>	_____	4	<u>Back Cover</u>
		X95-170040			49-0792
Top Cover (14)	5	<u>Pin Face Screw</u>	_____	6	<u>Aperture Dial Knob</u>
		43-5246			43-5245
	7	<u>Pin Face Screw</u>	_____	8	<u>Shutter Speed Dial</u>
		13-9489			Y00-1206
	9	<u>Screw x2</u>	_____	10	<u>Front Cover</u>
		X19-170256			43-5439
	11	<u>Front Cover</u>	_____	12	<u>Screw 12x2</u>
		43-5248			X16-170307
	13	<u>Disconnect leads</u>	_____	14	<u>Top Cover</u>
					49-0544

(Note) Don't turn Sleeve Gear. After removing Top Cover, mount Shutter Speed Dial on its original position.

1.2 Main Base Plate

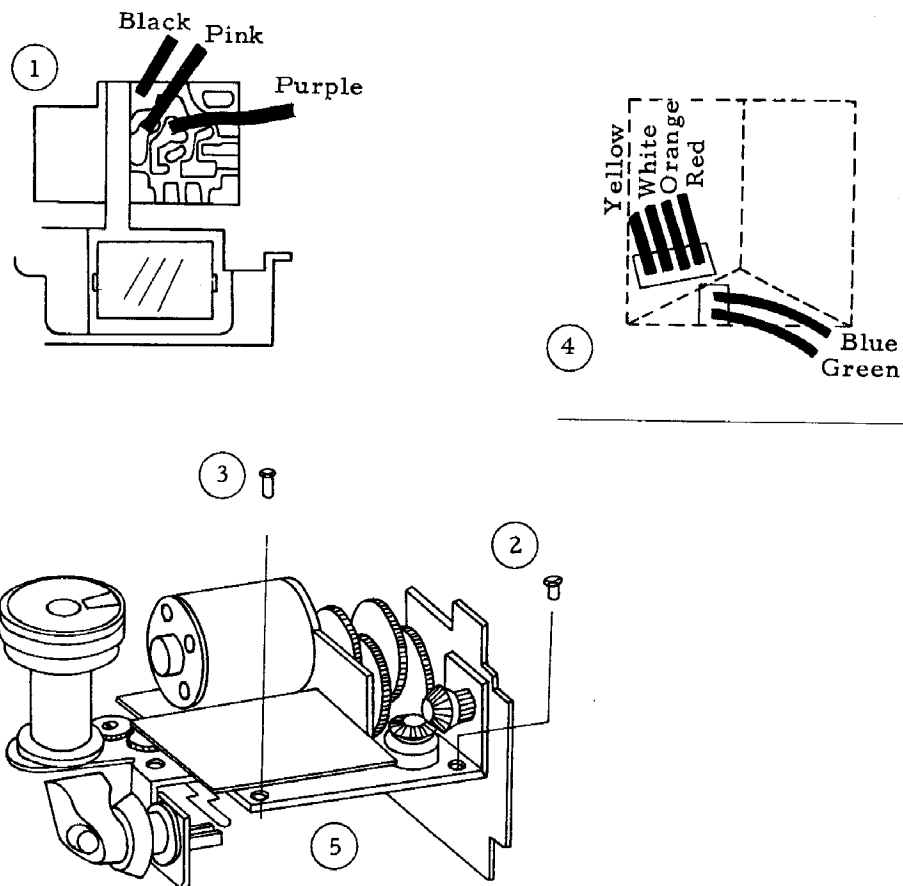

Remove the following parts in the sequence shown below:

- | | | | | |
|---|-----------------------------------|-------|---|-------------------------------|
| 1 | Disconnect leads | _____ | 2 | <u>Screw x2</u>
X18-200308 |
| 3 | <u>Screw x2</u>
X16-200308 | _____ | 4 | Disconnect leads |
| 5 | <u>Main Base Plate</u>
49-0559 | | | |

1.3 Pentaprism

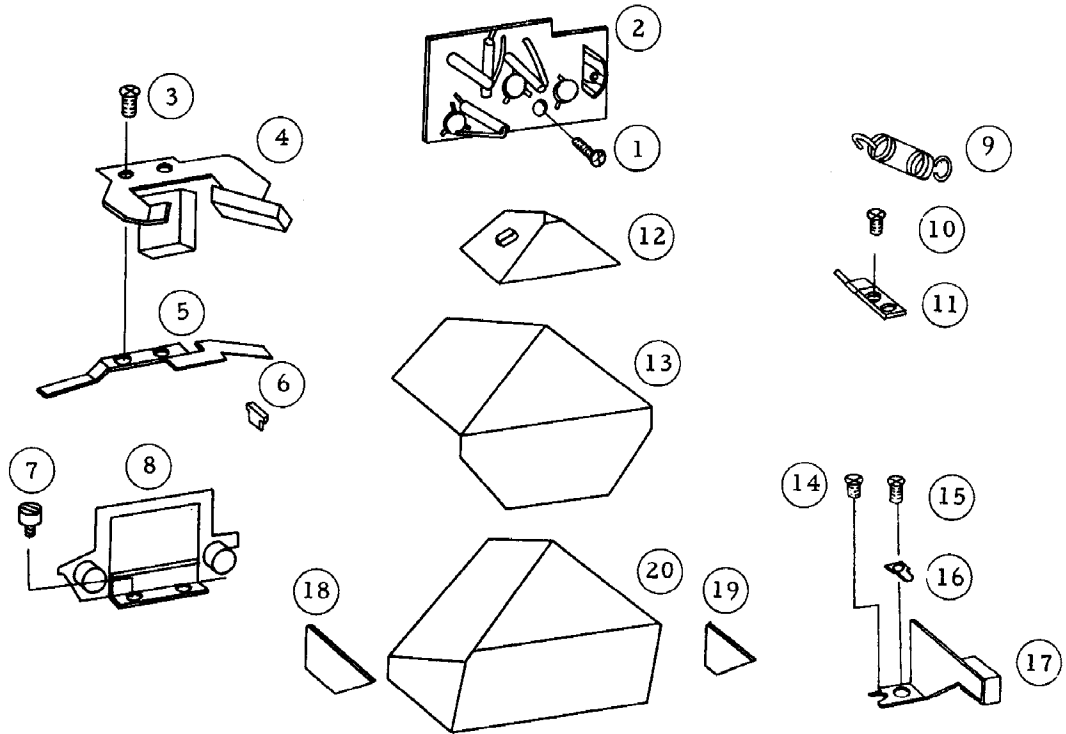

Remove the following parts in the sequence shown below:

- | | | | | | | |
|-----------------|----|-------------------------------------|----|--|----|--------------------------------|
| CdS (8) | 1 | <u>Screw</u>
X16-170308 | 2 | <u>Electric Parts Unit</u>
Y00-1264 | 3 | <u>Screw x2</u>
X16-170188 |
| | 4 | <u>Pentaprism Holder</u>
43-5442 | 5 | <u>Plate Spring</u>
97-7665 | 6 | <u>Pin</u>
13-9763 |
| | 7 | <u>Screw x2</u>
X91-173019 | 8 | <u>CdS</u>
49-0548 | | |
| Pentaprism (20) | 9 | <u>Spring x2</u>
97-5296 | 10 | <u>Screw</u>
X16-170188 | 11 | <u>Plate Spring</u>
97-7663 |
| | 12 | <u>Pentaprism Holder</u>
14-2071 | 13 | <u>Dust Cover</u>
43-5796 | | |
| | 14 | <u>Screw</u>
X16-170188 | 15 | <u>Screw</u>
X16-170228 | 16 | <u>Spring Plate</u>
43-5309 |
| | 17 | <u>CdS Unit</u>
49-075 | 18 | <u>Spacer</u>
13-9775 | 19 | <u>Spacer</u>
13-9774 |
| | 20 | <u>Pentaprism</u>
52-0045 | | | | |

1.4 EE Base Plate

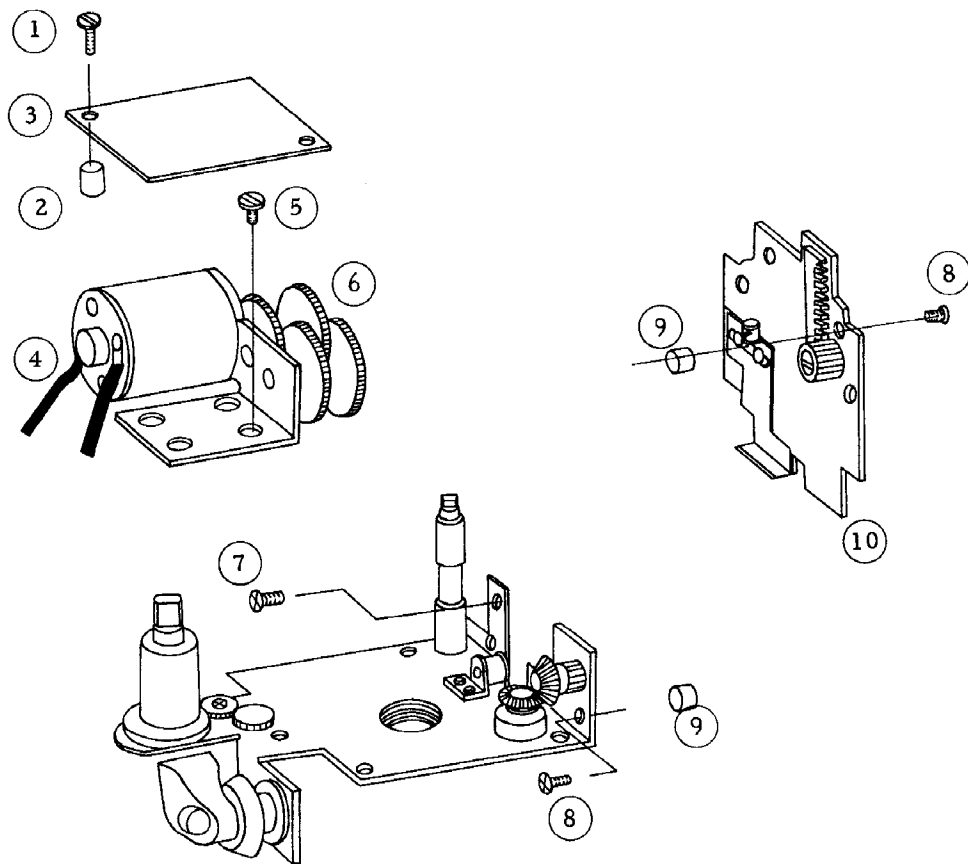

Remove the following parts in the sequence shown below:

- | | | | | |
|---------------------------|---|--|----|-------------------------------|
| Electronic Parts Unit (3) | 1 | <u>Screw x2</u>
X91-172489 | 2 | <u>Collar x2</u>
43-5235 |
| | 3 | <u>Electronic Parts Unit</u>
Y00-1265 | | |
| Motor Base Plate (6) | 4 | Disconnect 2 leads | 5 | <u>Screw x4</u>
X91-173131 |
| | 6 | <u>Motor Base Plate</u>
49-0545 | | |
| EE Base Plate (10) | 7 | <u>Screw x2</u>
X91-173539 | 8 | <u>Screw x3</u>
X91-173546 |
| | 9 | <u>Collar x3</u>
43-5252 | 10 | EE Base Plate |

2. Preliminary Adjustment

2.1 Lock Claw (43-5211) position

1. Check

Make sure that there is no masking of the finder information when the finder is installed on an F-1.

2. Adjustment

Change position of the lock claw utilizing the play in the screw hole for Screw (97-4325).

2.2 Clutch position

1. Checking

When the finder is installed on an F-1, the Shutter Speed Dial must turn smoothly.

2. Adjustment

Make adjustment with 3 Screws (X91-173538) for mounting Sleeve (43-5218).

2.3 Bulb switch

1. Contact (43-5266) (Sw 2) must be opened when the needle enters the lower warning mark, with the Shutter Speed Dial at "B".

2. Adjustment

Switch 3 must be closed at "B" and open at "1" sec on the shutter speed dial. Also, it must be switched at a position between "B" and "1" sec. Adjust the position of Contact Base (43-5274) with Screw (X16-170188).

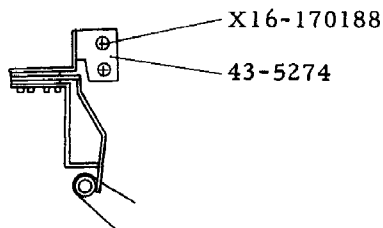

Fig. 1

2.4 Finder Information

1. Install the upper face of the rack gear 1.9mm below the upper face of EE Base Plate (43-5224).

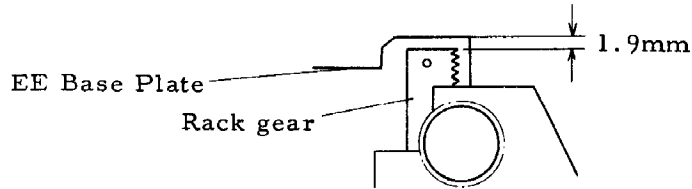

Fig. 2

2. Signal Plate

The figure of Max. F Dial must coincide with that at the upper part of the Signal Plate.

Make adjustment with the eccentric screw shown in Fig. 4.

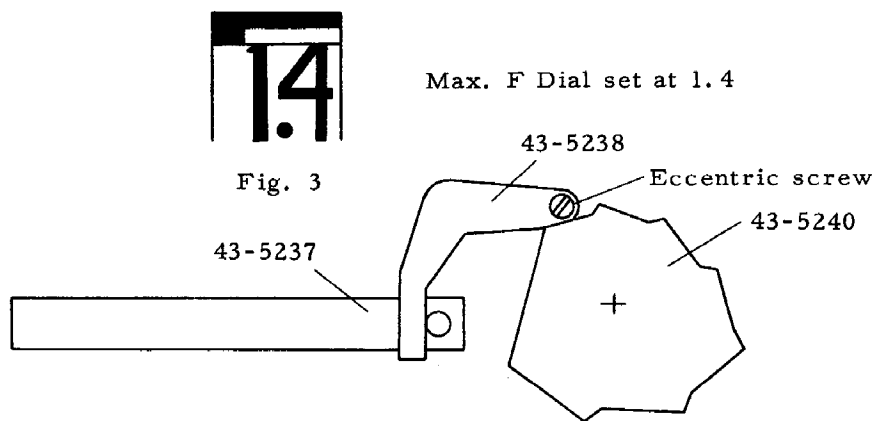

Fig. 4

3. Finder Needle

The needle should position at the center of the fig. 1.4. Make adjustment by bending the needle. (Fig. 5)

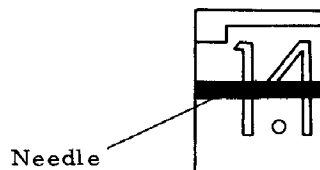

Fig. 5

2.5 Aperture Control Lever Position

1. Mount the Servo EE Finder on an F-1 installing the rack gear at the position 1.9mm under face of EE Base Plate. Mount an FD50mm 1 : 1.4 lens.
2. Adjustment:

Adjust Aperture Control Lever position by utilizing the slot of the lever so that EE Arm Pin 43-5261 contacts Aperture Control Lever 43-5231 properly, when EE Arm Lever 43-5260 of EE Arm touches the Signal Lever of the camera and the lens aperture is "OPEN".

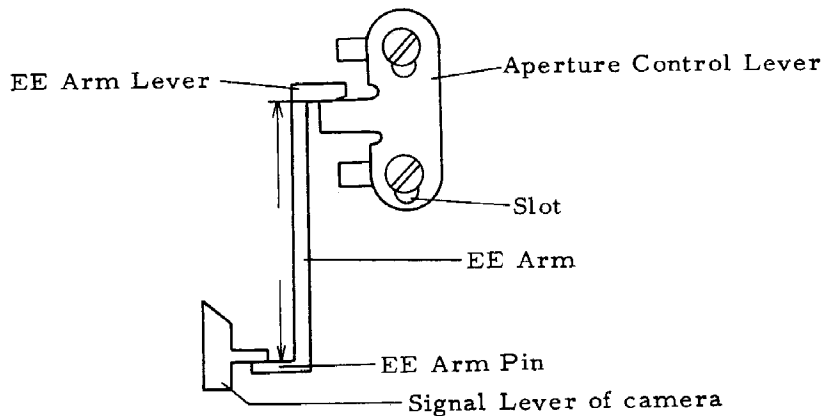

Fig. 6

2.6 Contacts (43-5271) and (43-5266)

1. Checking

The Aperture Control Lever should open the contact 0.4mm before the upper or lower ends of the EE Base Plate slot.

2. Adjustment:

Adjust the position of Contact 43-5271 or Contact 43-5266 with the respective Screw (X91-143531).

- 1) The limits for contact opening are 0.2 ~ 0.4mm before the end of the slot.
- 2) When Contact has opened, the needle must be in the warning mark.
- 3) Check the contact pressure by moving the Contact from ON to OFF position.

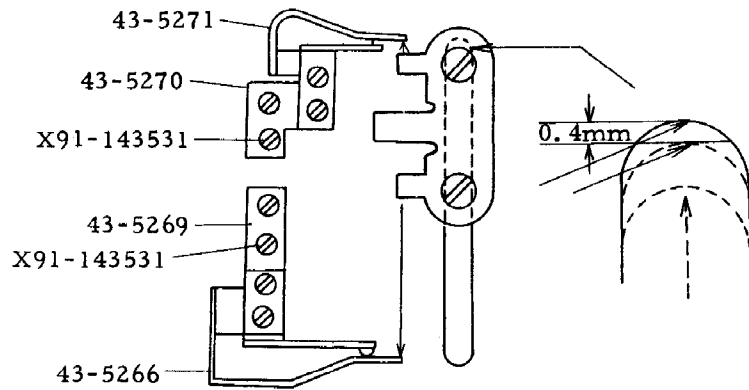

Fig. 7

3. EE Adjustment

Install the Servo EE finder on an F-1 after checking the position of Max. F Dial needle of the finder information as well as Aperture Control Lever position.

Mount a FD 50mm 1 : 1.4 Lens on the F-1. Set the power supply, to 12V.

3.1 Variable Resistor

Make adjustment by changing the engagement of Sleeve Gear 49-0549 with Gear so that the needle stops at the center of the figure "1.4" when applying a brightness of EV10 to the CdS, with the ASA set to ASA100 and the shutter speed to 1/500. See Fig. 8.

(Note) EV10 is 112.6 cd/m^2

3.2 Adjustment of EE accuracy

1. Check

- 1) Mount EE Arm.
- 2) Place the lens at the light source (Set lens to EE) (green circle).
- 3) Turn on Lever Switch.
- 4) Turn off the lever switch when the needle has stopped swinging.
- 5) Check the aperture diameter by pushing the Diaphragm Closing Lever of the Camera.

6) Compare the aperture diameter with the manual aperture.

K = 11

EV	cd/m ²	ASA	Shutter speed	Aperture	Standard value
9	56.3	100	125	2	± 0.6 EV
12	450.6	100	125	5.6	± 0.6 EV
14	1802.0	100	125	11	± 0.6 EV

2. Adjustment

Make adjustment by changing the engagement of Sleeve Gear 49-0549 with Gear (97-0750) (Fig. 8).

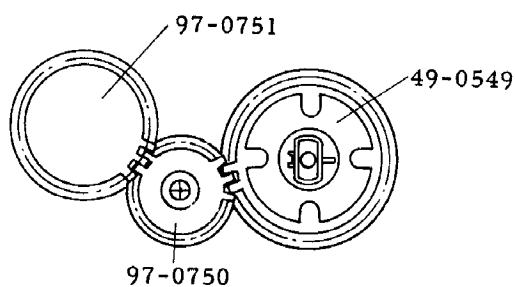

Fig. 8

- (Notes)
1. Replace CdS and variable resistor as a pair.
 2. EE Arm moves 2.15mm every EV changes.
 3. Don't adjust EE accuracy by bending the finder needle.
 4. Standards of EE accuracy
 - EV3 to EV7 ± 0.8EV
 - EV8 to EV14 ± 0.6EV
 - EV15 to EV19 ± 0.8EV

3.3 Checker

1. The checker lamp must come on or go off between 7.0 and 7.4V.

2. Adjustment

Make adjustment with VR5 on the Electronic Parts Unit (Y00-1263).

3.4 Miscellaneous

All servo mechanisms have certain limitations. These limitations have been minimized in the Servo EE Finder to the extent that they are negligible. These limitations are:

1. Insensitive zone: $\pm 0.2EV$
2. Overshoot: After a 5EV brightness change

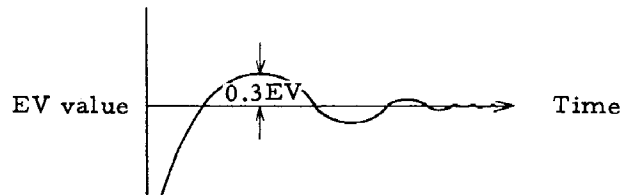

3. Reversing error and mechanical play in Shutter Dial. These are negligible in the Servo EE Finder due to close manufacturing tolerances.

4. Adjustment of backlash

Backlash of each gear must be minimum, and it must turn smoothly.

4.1 Motor and Reduction Gears

When installing Motor X61-2093 on Motor Base Plate 49-0545, adjust Motor position with Screw X16-200303.

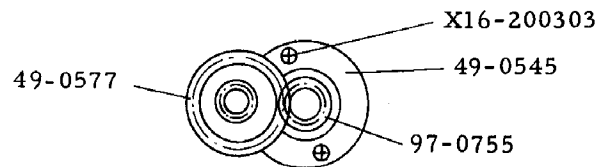

Fig. 9

4.2 Motor Base Plate and Main Base Plate

Adjust backlash by changing Motor Base Plate mounting position.

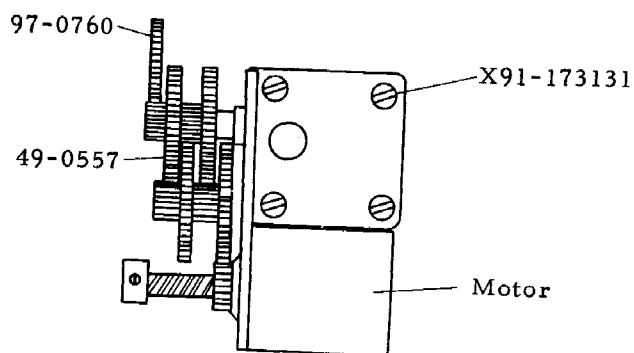

Fig. 10

4.3 Main Base Plate and EE Base Plate

Adjust backlash by utilizing play of the screw hole when installing EE Base Plate on Main Base Plate.

4.4 Gear

Obtain the proper position of Gear 49-0556 by using Washers (X32-502610 ~ 12).
Adjust the position of Gear 49-0555 by aligning the mounting position of Shaft Collar 43-5254.

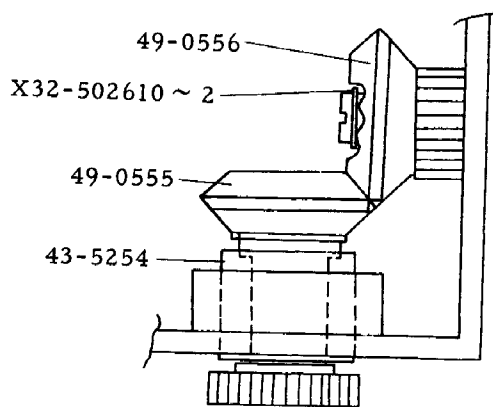

Fig. 11

4.5 Shutter Speed Dial Sleeve Gear (Shaft Gear)

Align the play of Sleeve Gear 49-0549 and Gear 97-0751 of the variable resistor by changing the mounting position of Gear 97-0750.

See Fig. 8.

5. Electric circuit

5.1 Selection of transistors

Measuring each current amplification ratio of Tr1 & 2, 3 & 4, 5 and 6, use pairs of transistors whose current amplification ratio is over 100 and difference of the ratio is within ± 5 . (Normally, replacement of the entire Electronic Parts Unit is recommended.)

5.2 Constant voltage power supply circuit

When the external power supply voltage is between 7 and 15V, the voltage supplied to the circuit must be 6 to 7V.

5.3 Bridge circuit

Make adjustment with VR2 so that the difference of voltage across Tr1 and Tr2 emitters is $\pm 1\text{mV}$ when energizing the power supply with the following stage disconnected (with R7 and R8 removed), employing the fixed resistor ($3.3\text{K}\Omega$) instead of the CdS variable resistor (VR1).

5.4 1st stage amplifier circuit

Make adjustment with VR3 so that the difference of voltage across Tr3 and Tr4 collectors is $\pm 3\text{mV}$ when the following stage is disconnected with R9, R14, R15 and R16 removed).

5.5 2nd stage amplifier circuit

Make adjustment with VR4 so that the difference of voltage across Tr5 and Tr6 collectors is $\pm 10\text{mV}$, connecting R9 and R14, and disconnecting R20 and R21.

(Note) Use an oscilloscope with a high input impedance or a vacuum-tube voltmeter.

CANON SERVICE TOOLS LIST

CANON SERVO EE FINDER
(REF. NO. 5-60101)

TEST EQUIPMENT

<u>Use</u>	<u>Names of Test Equipment</u>
Exposure Meter	1. Inspection Device for Canon Meter-1
	2. Standard Checker-2 (CdS)

SPECIAL SCREW DRIVERS

USE

T0630-13-8154-3

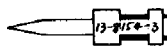

Tightening
Shutter Dial
(Common to FT)

T0630-13-8627-3

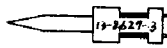

Tightening
Eyepiece
Shutter Dial
(Common to FT)

T06A-33-1408-2

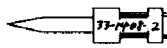

Tightening
Main Switch Lever
Pin Face Screw
(Common to Zoom 8)

T0631-43-5246-1



Tightening
Aperture Dial Knob
Pin Face Screw

EXPLODED VIEW of CANON SERVO EE FINDER

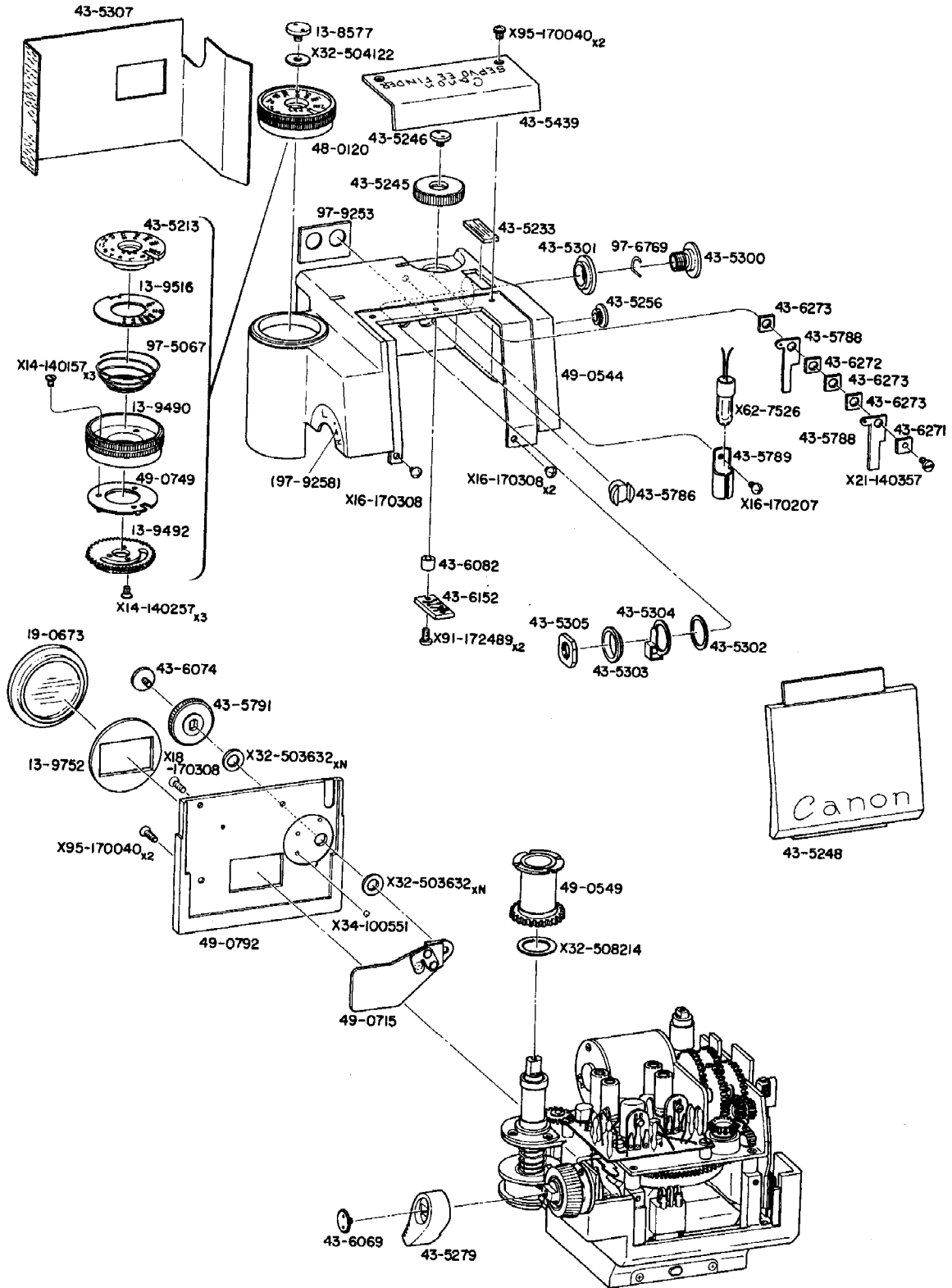

SCALE 1-2.0

PARTS LIST

TOP COVER & SHUTTER DIAL

上部カバー シャッターダイヤル

部 品 名 称	CLASS	PARTS NO.	QTY.	DESCRIPTION
カ ニ 目 ビ ス	D	13-8577	1	Pin Face Screw
シャッターダイヤルつまみ	D	13-9490	1	Knurled Knob
感 度 割 出 し 盤	D	13-9492	1	Film Speed Setting Disk
感 度 目 盛 盤	D	13-9516	1	Film Speed Dial
マ ス ク	D	13-9752	1	Mask
視 度 調 整 レ ン ズ	B	19-0673	1	Ocular
シャッターダイヤル	D	43-5213	1	Shutter Speed Dial
明 り 取 り 窓	D	43-5233	1	Window Glass
ダ イ ア ル つ ま み	D	43-5245	1	Aperture Dial Knob
カ ニ 目 ビ ス	B	43-5246	1	Pin Face Screw
前 カ バ ー	D	43-5248	1	Front Cover
メ イ ン ス イ ッ チ レ バ ー	D	43-5279	1	Main Switch Lever
ソ ケ ッ ト	D	43-5300	1	Socket
絶 縁 台	D	43-5301	1	Insulator Base
絶 縁 板	D	43-5302	1	Insulator
絶 縁 板	D	43-5303	1	Insulator
接 片	D	43-5304	1	Contact
ナ ッ ト	D	43-5305	1	Nut
レ ザ ー	B	43-5307	1	Leather
前 カ バ ー	B	43-5439	1	Front Cover
チ ェ ッ カ ー 釦	C	43-5786	1	Checker Button
接 片	D	43-5788	2	Contact
ラ ン プ 台	D	43-5789	1	Lamp Holder
シャッターつまみ	D	43-5791	1	Shutter Knob
カ ニ 目 ビ ス	C	43-6069	1	Pin Face Screw
カ ニ 目 ビ ス	C	43-6074	1	Pin Face Screw
絶 縁 板	D	43-6082	1	Insulator
ブ リ ン ト 板	D	43-6152	1	Printed Circuit Board
絶 縁 板	D	43-6271	1	Insulator
絶 縁 板	D	43-6272	1	Insulator
絶 縁 板	D	43-6273	3	Insulator
シャッタースピードダイヤル	B	48-0120	1	Shutter Speed Dial
上 部 カ バ ー	D	49-0544	1	Top Cover
ス リ ー ブ ギ ャ ー	D	49-0549	1	Sleeve Gear
裏 カ バ ー	D	49-0792	1	Back Cover
アイピースシャッター	D	49-0715	1	Eyepiece Shutter Blade
フ ィ ル ム 感 度 爪	D	49-0749	1	Film Speed Setting Claw
コ イ ル ス プ リ ン グ	D	97-5067	1	Coil Spring
ス プ リ ン グ	D	97-6769	1	Spring
チ ェ ッ カ ー プ レ ー ト	D	97-9253	1	Checker Plate
ス イ ッ チ プ レ ー ト	D	97-9258	1	Switch Plate
皿 ビ ス		X14-140157	3	Screw
皿 ビ ス		X14-140257	3	Screw
十 字 ナ ベ ビ ス		X16-170207	1	Screw
十 字 ナ ベ ビ ス		X16-170308	5	Screw
十 字 皿 ビ ス		X18-170308	1	Screw
平 ビ ス		X21-140357	1	Screw
ワ ッ シ ャ ー		X32-503632	N	Washer
ワ ッ シ ャ ー		X32-504122	N	Washer
ワ ッ シ ャ ー		X32-508214	1	Washer
ス チ ール ボ ール		X34-100551	1	Steel Ball
ラ ン プ	D	X62-7526	1	Lamp
平 ビ ス		X91-172489	2	Screw
丸 皿 ビ ス		X95-170040	4	Screw

EXPLODED VIEW
of
CANON SERVO EE FINDER

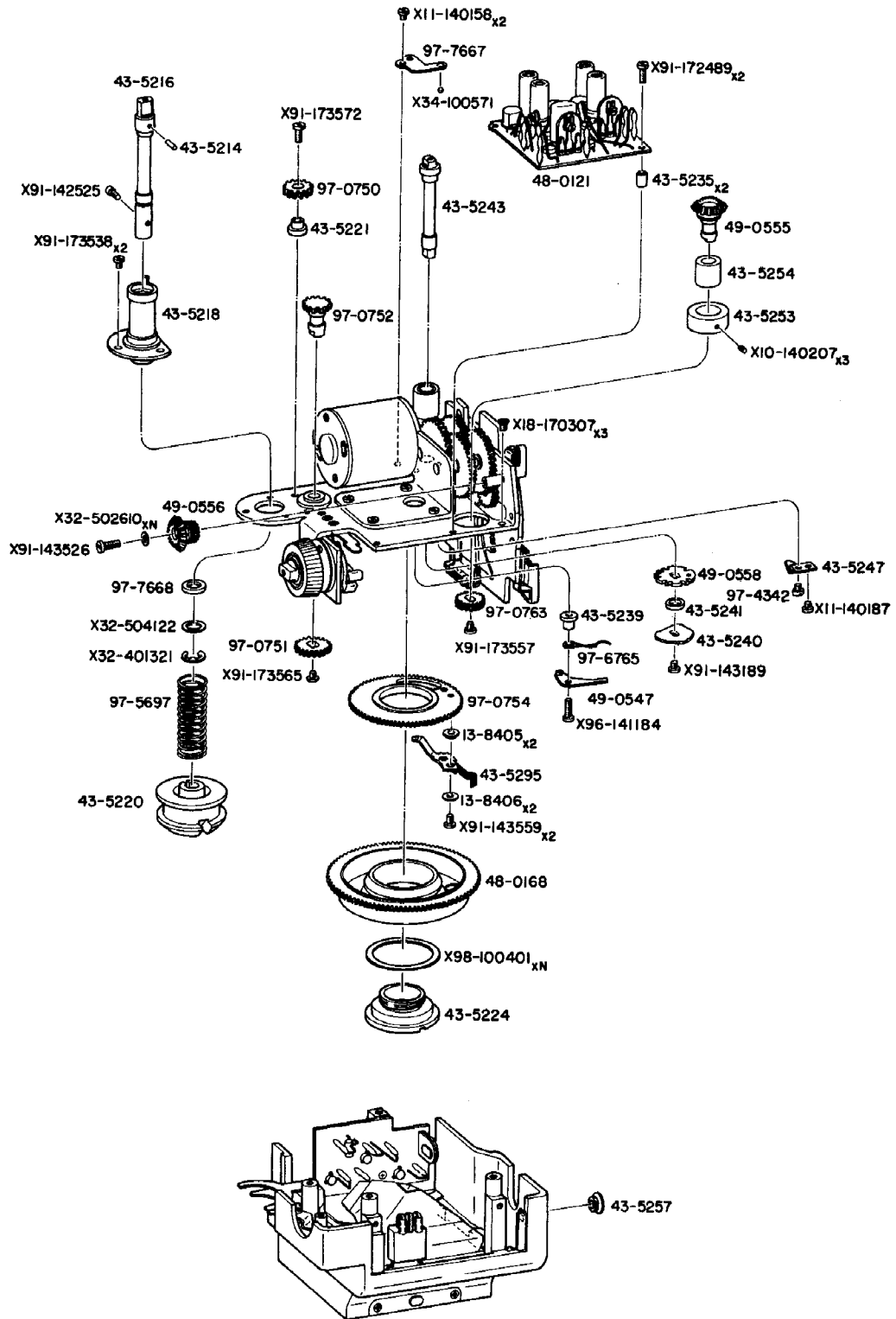

PARTS LIST

COUPLING & GEARS

カプリング ギヤー

部 品 名 称	CLASS	PARTS NO.	QTY.	DESCRIPTION
絶 縁 板	D	13-8405	2	Insulator
絶 縁 板	D	13-8406	2	Insulator
ピ ー ス	D	43-5214	1	Screw
シャッターダイヤル軸	D	43-5216	1	Shutter Dial Shaft
ス リ ー ブ	D	43-5218	1	Sleeve
カ プ リ ン グ	C	43-5220	1	Coupling
カ ラ ー	D	43-5221	1	Collar
力 押 環	D	43-5224	1	Assembly Collar
カ ラ ー	D	43-5235	2	Collar
錠 カ ラ ー	D	43-5239	1	Lock Button Catch
絞 リ カ ム	D	43-5240	1	Diaphragm Cam
カ ラ ー	D	43-5241	1	Collar
軸	D	43-5243	1	Shaft
カ ム ス ト ッ パ ー	D	43-5247	1	Cam Stopper
軸 受 け	D	43-5253	1	Bushing
軸 カ ラ ー	D	43-5254	1	Shaft Collar
ア ー ム ソ ケ ッ ト	D	43-5256	1	Arm Socket
ス リ ー ブ	D	43-5257	1	Sleeve
ブ ラ シ	D	43-5295	1	Resistor Wiper
電 気 部 品 ユ ニ ッ ト	C	48-0121	1	Electronics Parts Unit
C d S ユ ニ ッ ト	B	48-0168	1	CdS Unit
絞 リ レ バ ー	D	49-0547	1	Aperture Scale Lever
ギ ヤ ー	D	49-0555	1	Gear
ギ ヤ ー	D	49-0556	1	Gear
ク リ ッ ク リ ン グ	D	49-0558	1	Click Ring
ギ ヤ ー	D	97-0750	1	Gear
ギ ヤ ー	D	97-0751	1	Gear
ギ ヤ ー	D	97-0752	1	Gear
ギ ヤ ー	D	97-0754	1	Gear
ギ ヤ ー	D	97-0763	1	Gear
ピ ー ス	D	97-4342	1	Screw
コ イ ル ス プ リ ン グ	D	97-5697	1	Coil Spring
ス プ リ ン グ	D	97-6765	1	Spring
板 ス プ リ ン グ	D	97-7667	1	Plate Spring
ス プ リ ン グ ワ ッ シ ャ ー	D	97-7668	1	Spring Washer
止 め ピ ー ス		X10-140207	6	Screw
平 ピ ー ス		X11-140158	2	Screw
平 ピ ー ス		X11-140187	1	Screw
十 字 皿 ピ ー ス		X18-170307	3	Screw
緊 定 ワ ッ シ ャ ー		X32-401321	1	Retaining Washer
ワ ッ シ ャ ー		X32-502610	N	Washer
ワ ッ シ ャ ー		X32-504122	N	Washer
ス チ ール ボ ー ル		X34-100571	1	Steel Ball
平 ピ ー ス		X91-142525	1	Screw
平 ピ ー ス		X91-143189	1	Screw
平 ピ ー ス		X91-143526	2	Screw
平 ピ ー ス		X91-143559	2	Screw
平 ピ ー ス		X91-172489	2	Screw
平 ピ ー ス		X91-173538	3	Screw
平 ピ ー ス		X91-173557	1	Screw
平 ピ ー ス		X91-173565	1	Screw
平 ピ ー ス		X91-173572	1	Screw
段 ピ ー ス		X96-141184	1	Screw
ワ ッ シ ャ ー		X98-100401	N	Washer

EXPLODED VIEW
of
CANON SERVO EE FINDER

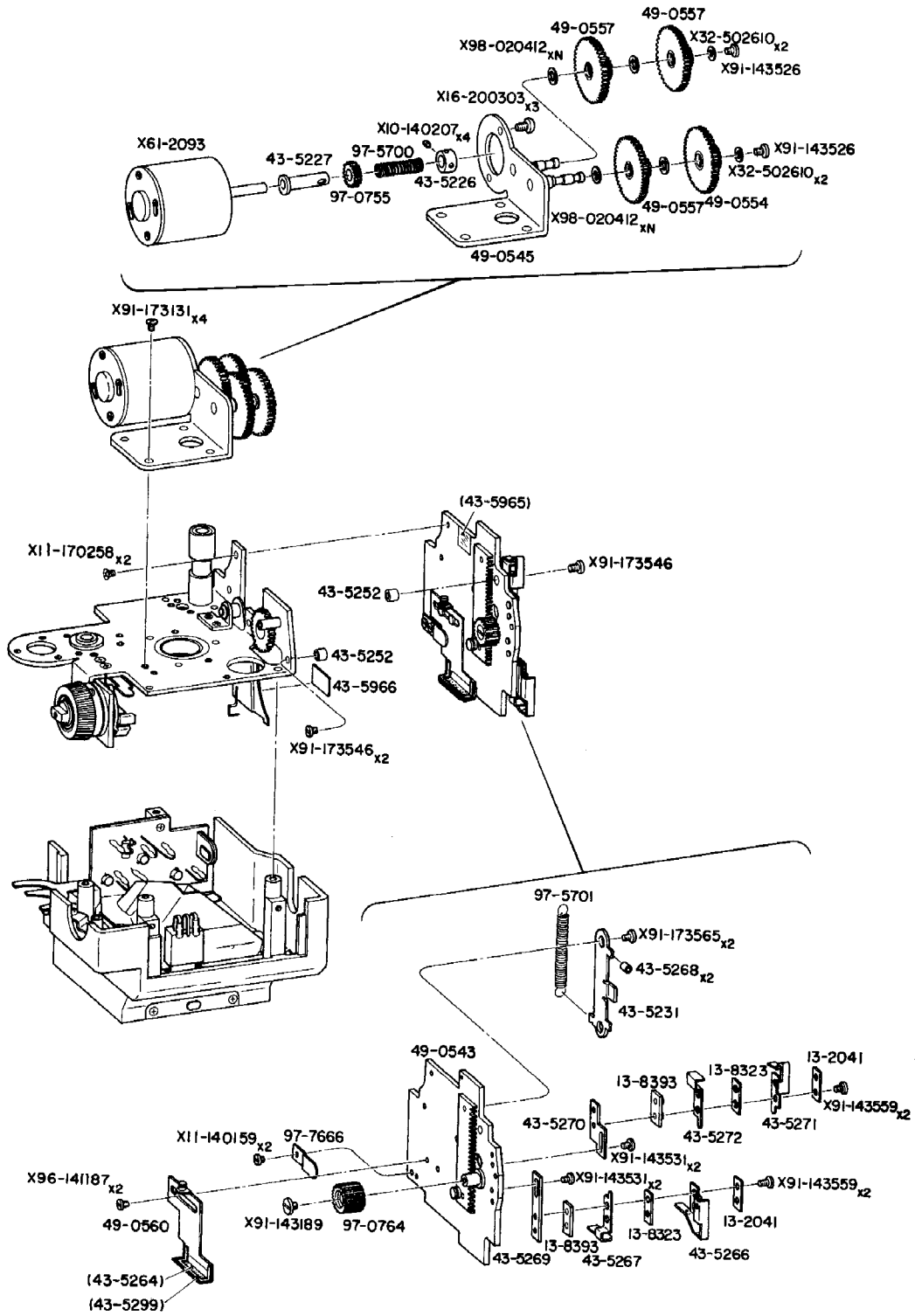

SCALE 1-2.0

© CANON INC.

PARTS LIST

MOTOR & EE MECHANISM

モーター EE 機構

部品名称	CLASS	PARTS NO.	QTY.	DESCRIPTION
絶縁板	D	13-2041	2	Insulator
絶縁板	D	13-8323	2	Insulator
絶縁板	D	13-8393	2	Insulator
ナット	D	43-5226	1	Nut
ギヤ軸	D	43-5227	1	Shaft Sleeve
絞り連動レバー	D	43-5231	1	Aperture Control Lever
力率	D	43-5252	2	Collar
絞り目盛板	C	43-5264	1	Aperture Scale
接触片	D	43-5266	1	Contact
接触片	D	43-5267	1	Contact
絶縁チューブ	D	43-5268	2	Insulator
接触片	D	43-5269	1	Contact Base
接触片	D	43-5270	1	Contact Base
接触片	D	43-5271	1	Contact
接触片	D	43-5272	1	Contact
警告マーク	C	43-5299	1	Warning Mark
反射板	D	43-5965	1	Reflector
反射板	D	43-5966	1	Reflector
EE地板	D	49-0543	1	EE Base Plate
モーター地板	D	49-0545	1	Motor Base Plate
ギヤ	D	49-0554	1	Gear
ギヤ	D	49-0557	3	Gear
開口補正板	D	49-0560	1	Max. Aperture Correction Plate
ギヤ	D	97-0755	1	Gear
ギヤ	D	97-0764	1	Gear
コイルスプリング	D	97-5700	1	Coil Spring
コイルスプリング	D	97-5701	1	Coil Spring
板スプリング	D	97-7666	1	Plate Spring
止めビス		X10-140207	4	Screw
平ビス		X11-140159	2	Screw
平ビス		X11-170258	2	Screw
十字ナベビス		X16-200303	3	Screw
ワッシャー		X32-502610	N	Washer
モーター	C	X61-2093	1	Motor
平ビス		X91-143189	1	Screw
平ビス		X91-143526	2	Screw
平ビス		X91-143531	1	Screw
平ビス		X91-143559	4	Screw
平ビス		X91-173131	4	Screw
平ビス		X91-173546	3	Screw
平ビス		X91-173565	2	Screw
段ビス		X96-141187	2	Screw
ワッシャー		X98-020412	N	Washer

EXPLODED VIEW of CANON SERVO EE FINDER

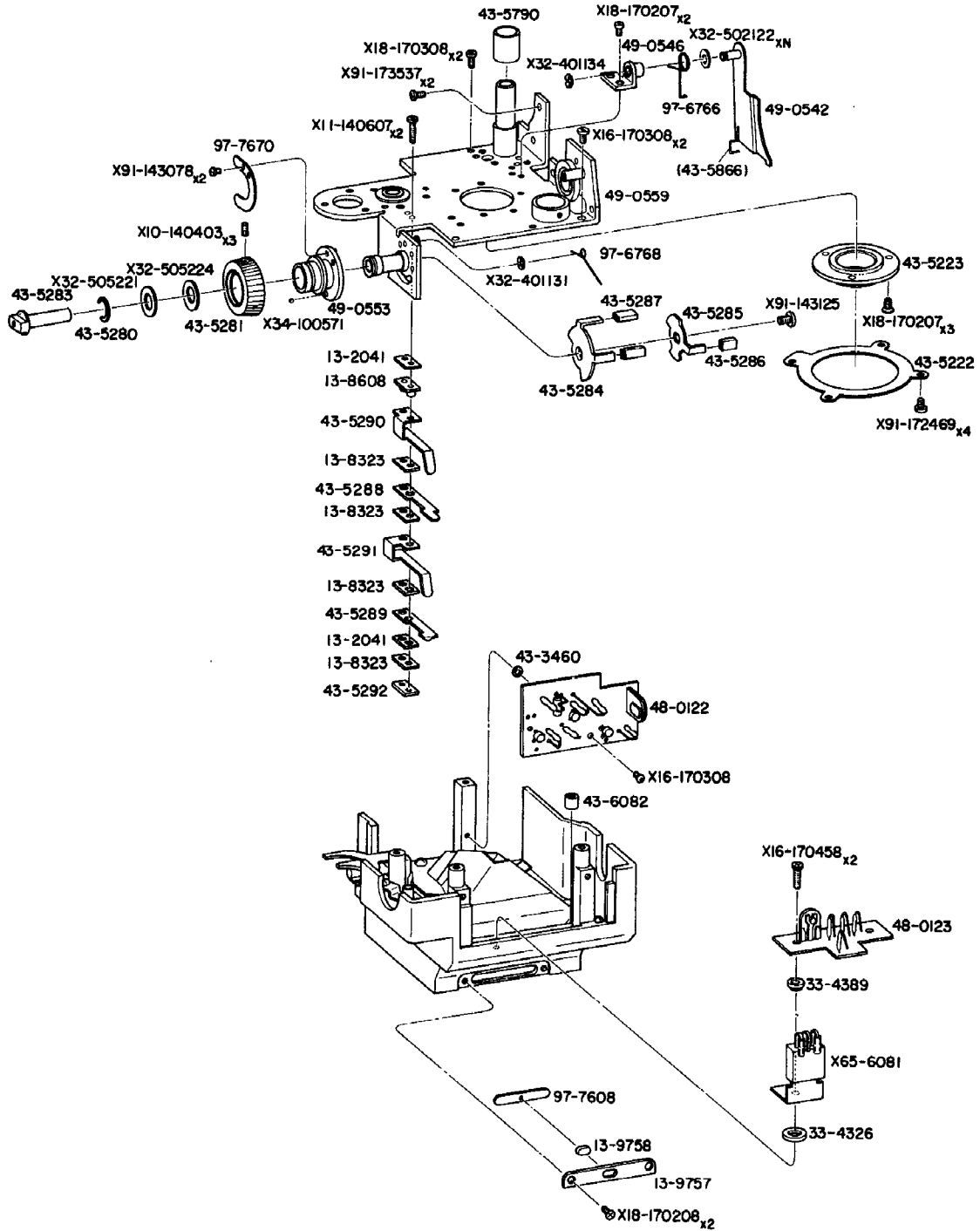

SCALE 1-2.0

© CANON INC.

PARTS LIST

MAIN BASE PLATE & SWITCH RING

主 地 板 スイッチ リング

部 品 名 称	CLASS	PARTS NO.	QTY.	DESCRIPTION
絶 縁 板	D	13-2041	2	Insulator
絶 縁 板	D	13-8323	4	Insulator
絶 縁 台	D	13-8608	1	Insulator
押 え 板	D	13-9757	1	Plate
セ ッ ト ピ ン	D	13-9758	1	Set Pin
絶 縁 板	D	33-4326	1	Insulator
絶 縁 台	D	33-4389	1	Insulator Base
絶 縁 ワ ッ シ ャ ー	D	43-3460	1	Washer
プ リ ン ト 板	D	43-5222	1	Printed Circuit Board
軸 受 け	D	43-5223	1	Gear Holder
ワ ッ シ ャ ー	D	43-5280	1	Washer
ス イ ッ チ リ ン グ	C	43-5281	1	Switch Ring
ス イ ッ チ レ バ ー 軸	D	43-5283	1	Switch Lever Shaft
板 ス プ リ ン グ	D	43-5284	1	Plate Spring
ス イ ッ チ レ バ ー	D	43-5285	1	Switch Lever
絶 縁 チ ュ ー ブ	D	43-5286	2	Insulator Tube
絶 縁 チ ュ ー ブ	D	43-5287	2	Insulator Tube
接 触 片	D	43-5288	1	Contact
接 触 片	D	43-5289	1	Contact
接 触 片	D	43-5290	1	Contact
接 触 片	D	43-5291	1	Contact
絶 縁 板	D	43-5292	1	Insulator
絶 縁 チ ュ ー ブ	D	43-5790	1	Insulator Tube
追 針	C	43-5866	1	Following Needle
絶 縁 板	D	43-6082	1	Insulator
電 気 部 品 ユ ニ ッ ト	C	48-0122	1	Electronics Parts Unit
電 気 部 品 ユ ニ ッ ト	C	48-0123	1	Electronics Parts Unit
カ ム 板	C	49-0542	1	Cam Plate
カ ム 軸 支 え	D	49-0546	1	Cam Support
ス イ ッ チ リ ン グ	D	49-0553	1	Switch Ring
主 地 板	D	49-0559	1	Main Base Plate
ス プ リ ン グ	D	97-6766	1	Spring
ス プ リ ン グ	D	97-6768	1	Spring
板 ス プ リ ン グ	D	97-7608	1	Plate Spring
板 ス プ リ ン グ	D	97-7670	1	Plate Spring
止 め ビ ス		X10-140403	3	Screw
平 ビ ス		X11-140607	2	Screw
十 字 ナ ベ ビ ス		X16-170308	3	Screw
十 字 ナ ベ ビ ス		X16-170458	2	Screw
十 字 皿 ビ ス		X18-170207	5	Screw
十 字 皿 ビ ス		X18-170208	2	Screw
十 字 皿 ビ ス		X18-170308	2	Screw
緊 定 ワ ッ シ ャ ー		X32-401131	2	Retaining Washer
緊 定 ワ ッ シ ャ ー		X32-401134	1	Retaining Washer
ワ ッ シ ャ ー		X32-502122	N	Washer
調 整 ワ ッ シ ャ ー		X32-505221	N	Adjusting Washer
		X32-505222		
ワ ッ シ ャ ー		X32-505224	1	Washer
ス テ ー ル ボ ー ル		X34-100571	1	Steel Ball
ト ラ ン ジ ス タ ー		X61-6081	1	Transistor
平 ビ ス		X91-143078	2	Screw
平 ビ ス		X91-143125	1	Screw
平 ビ ス		X91-172469	4	Screw
平 ビ ス		X91-173537	2	Screw

EXPLODED VIEW
of
CANON SERVO EE FINDER

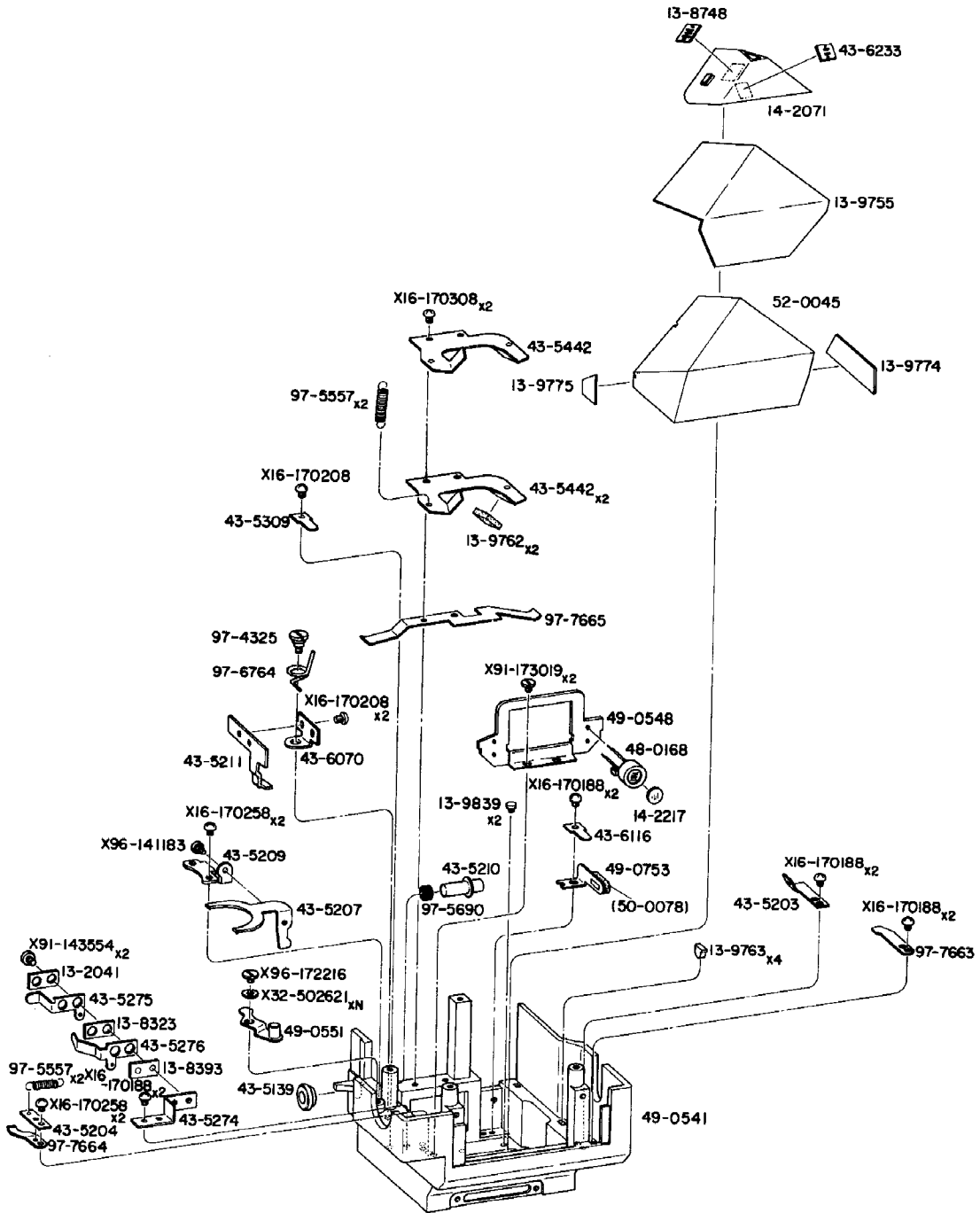

SCALE 1-2.0

© CANON INC.

